

one stop shop for  
**BRAKE WHEELS**  
**DISCS & COUPLINGS**

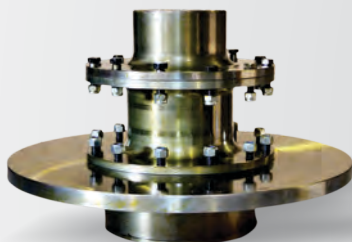

one stop shop for

**BRAKE WHEELS**

**DISCS & COUPLINGS**



VTND PRODUCTS INC.

VTND Products Inc. brake wheels are manufactured at ISO 9001:2015 certified foundry, from specially formulated ductile iron casting. Ductile iron has great strength is easily machinable and resistant to scoring. It is compatible with a variety of friction materials to allow for smooth and even wear. Wheels are fully machined to allow for proper balance at normal speeds. Wheels are supplied semi-finished with a pilot bore. Alternatively, they can be supplied fully machined with a parallel (straight) or taper(conical) bore and keyway.

## TYPE OT1BW BRAKE WHEEL

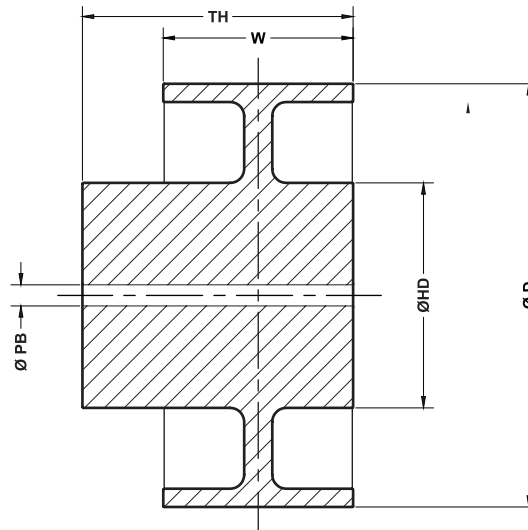

WHEEL DIAMETER	BRAKE WHEEL WIDTH	TOTAL HEIGHT	HUB DIAMETER	PILOT BORE	WEIGHT	MAXIMUM BORE SIZE
D	W	TH	HD	PB	lbs*	Inches
4"	2.250	3.250	3.000	0.250	9	1.875
6"	3.250	5.000	3.000	0.500	16	1.875
8"	4.250	6.500	4.250	0.500	36	2.660
10"	4.250	6.500	4.500	0.750	49	2.660
13"	5.750	8.500	5.750	0.750	104	3.600
15"	6.750	9.500	8.000	0.750	198	5.000
16"	6.750	9.625	8.000	0.750	210	5.000
19"	8.750	13.250	9.250	2.000	358	6.000

All dimensions are in inches Additional sizes available upon request

\*weight subject to variation - Please contact customer care

\*Dimensions are subjected to change without prior notice



VTND PRODUCTS INC.

one stop shop for

**BRAKE WHEELS**

**DISCS & COUPLINGS**

### Standard Features

- Manufactured from Ductile Iron
- Completely machined to provide proper balance at normal speed
- Resistant to scoring
- Wears smoothly and evenly

### Optional Features

- Chrome plated friction path
- Finished Bore - Tapered and Parallel
- Lockwasher slot
- Dynamic Balancing

## TYPE AT2BW BRAKE WHEEL

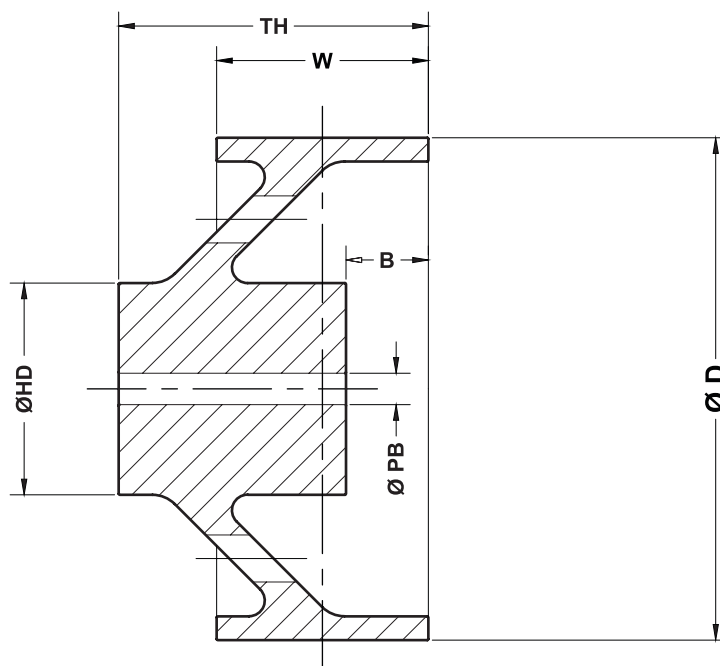

WHEEL DIAMETER	BRAKE WHEEL WIDTH	TOTAL HEIGHT	HUB DIAMETER	BRAKE FACE TO HUB	PILOT BORE	WEIGHT	MAXIMUM BORE SIZE
D	W	TH	HD	B	PB	lbs*	Inches
5"	2.750	4.000	4.000	0.625	0.250	16	2.500
8"	3.250	6.500	3.875	0.500	0.750	34	2.375
10"	3.750	6.875	4.875	0.875	0.750	56	3.000
13"	5.750	9.125	6.813	1.250	0.875	130	4.250
16"	6.750	9.875	6.750	2.625	1.000	163	4.250
19"	8.750	12.375	7.000	4.125	1.000	271	4.375
23"	11.250	14.500	9.500	5.500	1.000	494	5.000
30"	14.250	19.875	13.500	7.125	2.000	1140	7.000

All dimensions are in inches Additional sizes available upon request

\*weight subject to variation - Please contact customer care

\*Dimensions are subjected to change without prior notice

### TYPE CT3BW BRAKE WHEEL

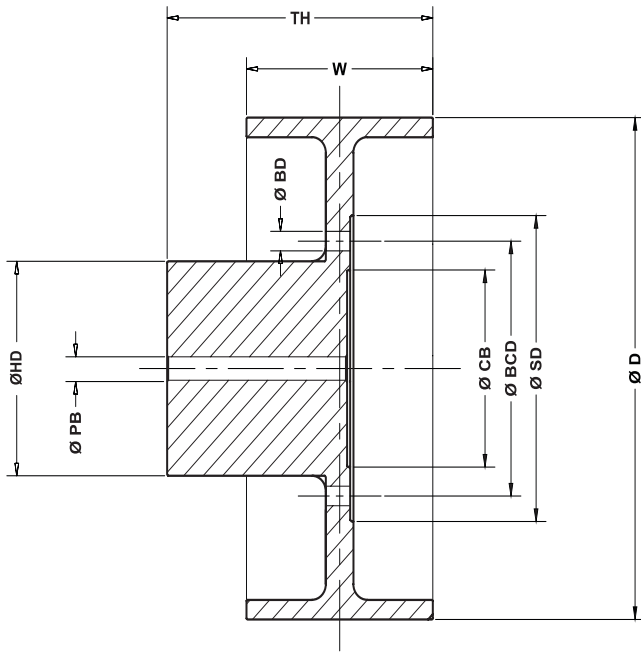

### TYPE C2T3BW BRAKE WHEEL

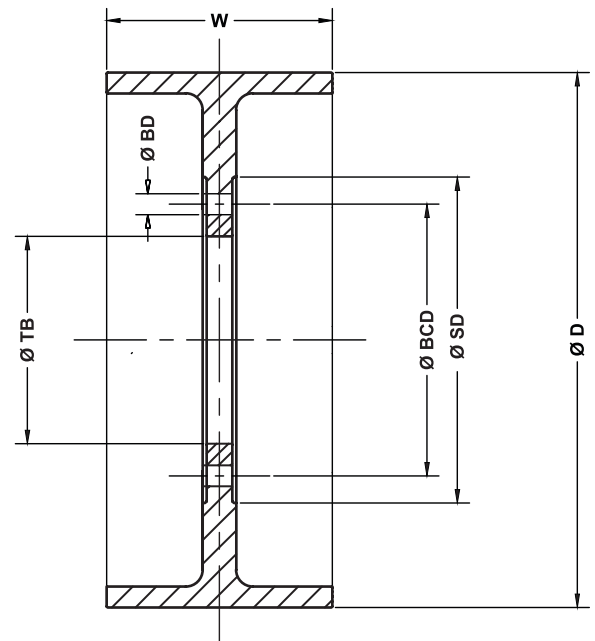

WHEEL DIAMETER	BRAKE WHEEL WIDTH	TOTAL HEIGHT	HUB DIAMETER	SLEEVE DIAMETER	BOLT CIRCLE DIAMETER	PILOT BORE	WEIGHT	MAXIMUM BORE SIZE
D	W	TH	HD	SD	BCD	PB	lbs*	Inches
10"	4.250	6.500	4.000	6.000	4.813	0.750	37	2.500
12"	5.250	8.000	4.860	7.000	5.875	0.750	65	3.000
13"	5.750	8.500	4.860	7.000	5.875	0.750	76	3.000
13"	5.750	8.500	5.750	8.625	7.125	0.750	81	3.625
15"	6.750	9.500	5.840	8.375	7.125	0.750	123	3.625
15"	6.750	9.500	6.840	9.438	8.125	0.750	137	4.250
16"	6.750	9.625	5.840	8.375	7.125	0.750	133	3.625
16"	6.750	9.625	6.840	9.438	8.125	0.750	147	4.250

All dimensions are in inches Additional sizes available upon request

\*weight subject to variation - Please contact customer care

\*Dimensions are subjected to change without prior notice





VTND PRODUCTS INC.

one stop shop for

**BRAKE WHEELS**

**DISCS & COUPLINGS**

## GEAR COUPLINGS

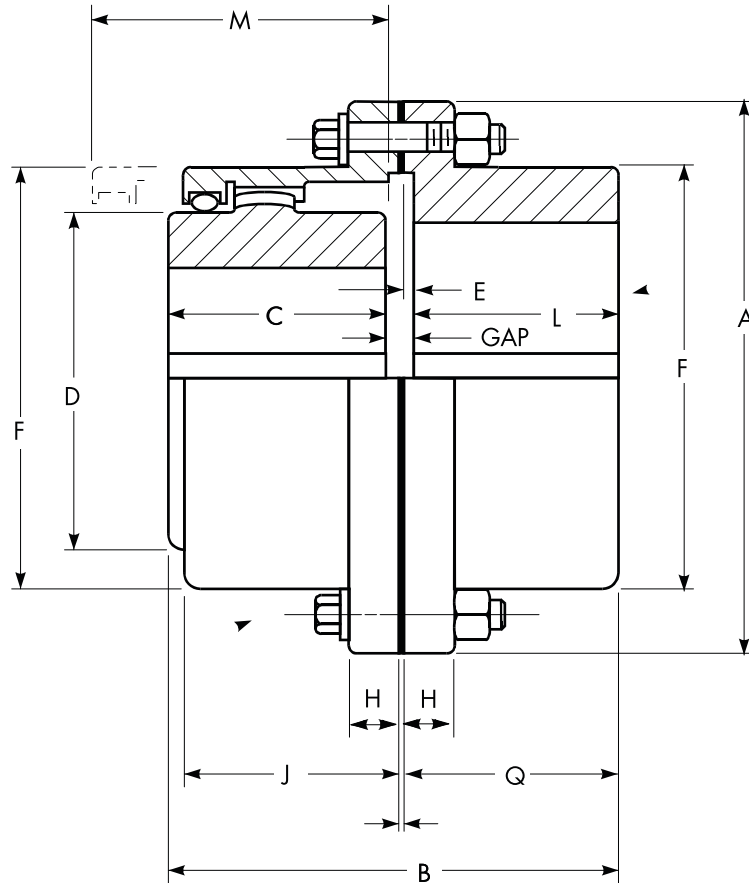

### Dimensions (in)

Size ≠	Torque Rating (lb-in) Æ	Allow Speed RPM Ø	Max Bore ∞		Min Bore ±	Cplg Wt with No Bore (lb)		Lube Wt (lb)	A	B	C	D	E	F	H	J	L	M	Q	GAP
			Flex Hub	Rigid Hub		G51	G52													
1010G	10,080	8,000	1.875	2.375	0.50	9	10	0.05	4.56	3.41	1.69	2.70	0.10	3.30	0.55	1.53	1.56	2.00	1.66	0.156
1015G	20,790	6,500	2.375	2.938	0.75	18	20	0.09	6.00	3.92	1.94	3.40	0.10	4.14	0.75	1.88	1.82	2.40	1.92	0.156
1020G	37,800	5,600	2.875	3.625	1.00	30	35	0.15	7.00	4.90	2.44	4.14	0.10	4.98	0.75	2.34	2.30	3.00	2.40	0.156
1025G	66,150	5,000	3.625	4.375	1.25	55	60	0.26	8.38	6.12	3.03	5.14	0.10	6.10	0.86	2.82	2.90	3.60	3.00	0.188
1030G	107,100	4,400	4.125	5.125	1.50	85	95	0.40	9.44	7.24	3.59	6.00	0.10	7.10	0.86	3.30	3.46	4.20	3.56	0.188
1035G	163,800	3,900	4.875	5.875	2.00	135	150	0.60	11.00	8.43	4.19	7.00	0.10	8.32	1.12	3.84	4.02	5.10	4.12	0.218
1040G	270,900	3,600	5.750	7.250	2.50	200	220	1.03	12.50	9.56	4.75	8.25	0.16	9.66	1.12	4.38	4.54	5.70	4.70	0.281
1045G	371,700	3,200	6.750	8.125	3.00	285	300	1.25	13.62	10.75	5.31	9.25	0.16	10.79	1.12	4.84	5.14	6.50	5.30	0.312
1050G	500,900	2,900	7.375	9.000	3.50	400	430	2.00	15.31	12.17	6.03	10.00	0.20	12.04	1.50	5.54	5.80	7.20	6.00	0.344
1055G	655,200	2,650	8.250	10.000	4.00	555	580	2.50	16.75	13.76	6.62	11.00	0.20	13.16	1.50	6.22	6.80	8.00	7.00	0.344
1060G	800,100	2,450	9.125	11.000	4.50	-	715	3.75	18.00	15.16	7.41	12.00	0.26	14.41	1.00	6.66	7.34	9.00	7.60	0.406
1070G	1,197,000	2,150	10.875	13.000	5.00	-	1120	5.00	20.75	17.86	8.69	14.00	0.33	16.73	1.12	7.70	8.67	10.50	9.00	0.500

All dimensions are in inches Additional sizes available upon request

\*weight subject to variation - Please contact customer care

\*Dimensions are subjected to change without prior notice

## DISC ASSEMBLIES

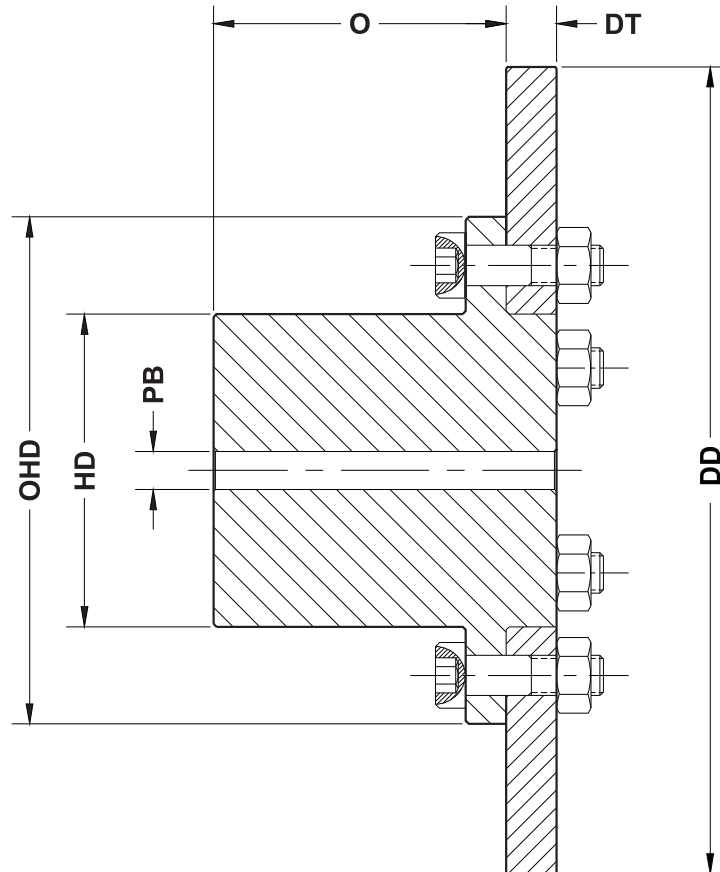

DISC ASSEMBLY	HUB DIAMETER	OFFSET	OVERALL HUB DIAMETER	DISC DIAMETER	DISC THICKNESS	PILOT BORE	MAXIMUM BORE SIZE
	HD	O	OHD	DD	DT	PB	Inches
DA-1010	3.110"	1.650"	4.560"	Information Supplied By Customer		0.250"	1.940"
DA-1015	3.910"	1.920"	6.000"			0.500"	2.440"
DA-1020	4.880"	2.380"	7.000"			0.500"	3.000"
DA-1025	5.910"	3.000"	8.380"			0.750"	3.690"
DA-1030	6.880"	3.500"	9.440"			1.000"	4.250"
DA-1035	7.910"	4.060"	11.000"			1.000"	4.940"

All dimensions are in inches Additional sizes available upon request

\*weight subject to variation - Please contact customer care

\*Dimensions are subjected to change without prior notice



VTND PRODUCTS INC.

one stop shop for

**BRAKE WHEELS**

**DISCS & COUPLINGS**

### QUOTE REQUEST FORM

COMPANY : \_\_\_\_\_

CONTACT : \_\_\_\_\_

E-MAIL : \_\_\_\_\_

PHONE : \_\_\_\_\_

FAX : \_\_\_\_\_

In order to provide an accurate quote please fill in as much information as possible

Please send this form to [sales@rotatorproducts.com](mailto:sales@rotatorproducts.com)

### STEP 1 : INDICATE BRAKE WHEEL TYPE

Please Quote Brake Wheel Type OT1BW

Diameter (D): \_\_\_\_\_

Wheel Width (W): \_\_\_\_\_

Total Height (TH): \_\_\_\_\_

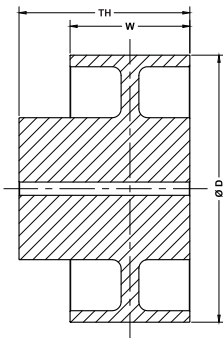

Please Quote Brake Wheel Type AT2BW

Diameter (D): \_\_\_\_\_

Wheel Width (W): \_\_\_\_\_

Total Height (TH): \_\_\_\_\_

Depth (B) : \_\_\_\_\_

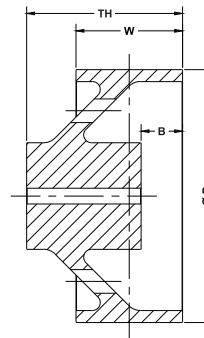

### STEP 2 : INDICATE BORE DIMENSIONS

Bore Diameter: \_\_\_\_\_

Key Way Width: \_\_\_\_\_

Key Way Depth: \_\_\_\_\_

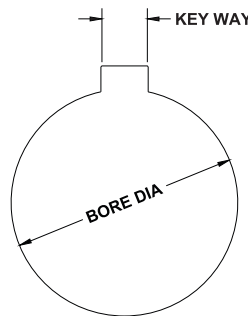

#### Bore Type

Parallel (Straight) Bore

OR

Tapered (Conical) Bore

Taper \_\_\_\_\_ IN/FT on Diameter

### STEP 3 : INDICATE ANY OPTIONS REQUIRED

CHROME PLATED FRICTION PATH

BENT LOCK WASHER SLOT

DYNAMIC BALANCING

SET SCREWS

### COMMENTS OR SPECIAL REQUESTS



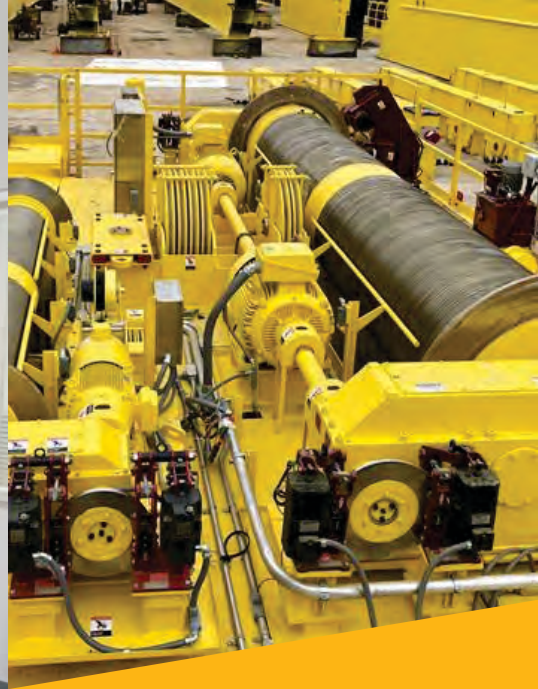

*one stop shop for*

**BRAKE WHEELS**

**DISCS & COUPLINGS**

Marketed in North America by

**ROTATOR PRODUCTS LIMITED**

**[sales@rotatorproducts.com](mailto:sales@rotatorproducts.com)**

**1-877-682-8671**

